

EN

OPERATING MANUAL
PARTICLE COUNTER



Table of contents

Notes regarding the operating manual..... 1

Safety 2

Information about the device..... 4

Technical data 6

Transport and storage..... 7

Operation 7

Maintenance and repair 12

Disposal 13

Notes regarding the operating manual

Symbols

 **Warning of electrical voltage**
This symbol indicates dangers to the life and health of persons due to electrical voltage.

 **Warning of explosive substances**
This symbol indicates dangers to the life and health of persons due to potentially explosive substances.

 **Warning of laser radiation**
This symbol indicates dangers to the health of persons due to laser radiation.

 **Warning**
This signal word indicates a hazard with an average risk level which, if not avoided, can result in serious injury or death.

 **Caution**
This signal word indicates a hazard with a low risk level which, if not avoided, can result in minor or moderate injury.

Notice
This signal word indicates important information (e.g. material damage), but does not indicate hazards.

 **Info**
Information marked with this symbol helps you to carry out your tasks quickly and safely.

 **Follow the manual**
Information marked with this symbol indicates that the operating manual must be observed.

You can download the current version of the operating manual and the EU declaration of conformity via the following link:



PC220



<http://hub.trotec.com/?id=40529>

Definitions

Concept	Meaning
Differential (Analysis)	The device counts the effectively measured particles per separate channel within the set measuring period. There is no averaging as in <i>concentration</i> mode. Measuring in <i>differential</i> mode is therefore more precise. Example: The measuring device shows 100 particles in the 0.3 µm channel and 30 in the 0.5 µm channel. The differential data is 100 particles > 0.3 µm and < 0.5 µm, and 30 particles > 0.5 µm.
Wet-bulb temperature	The wet-bulb temperature is the lowest temperature below the current surrounding conditions which can be reached by the evaporation of water.
Coincidence loss	When measuring high concentrations of particles, it may happen that two particles are so close to each other that they are counted as one (mostly larger) particle.
Concentration (Analysis)	Adding up of the measured values per separate channel directly from the first seconds of a measurement. Every second of the running measuring period the device calculates the respective average per channel from the determined values and the resulting volume.
Cumulative (Analysis)	This is a summation of the individual particle sizes in the channel of the next smaller particle size respectively located beneath. Exemplary display: - 5µ = 26 - 10µ = 14 Then only 12 particles of the size 5µ were measured. 12 + 14 = 26
Counting efficiency	The counting efficiency specifies the probability at which a particle of the smallest detectable size is detected and counted during the measurement. For particles larger than the smallest detectable size, the counting efficiency is 100 %.

Safety

Read this manual carefully before starting or using the device. Always store the manual in the immediate vicinity of the device or its site of use!

- Do not use the device in potentially explosive rooms.
- Do not use the device in aggressive atmosphere.
- Do not immerse the device in water. Do not allow liquids to penetrate into the device.
- The device may only be used in dry surroundings and must not be used in the rain or at a relative humidity exceeding the operating conditions.
- Protect the device from permanent direct sunlight.
- Do not remove any safety signs, stickers or labels from the device. Keep all safety signs, stickers and labels in legible condition.
- Do not open the device with a tool.
- Only use the device if sufficient safety precautions were taken at the surveyed location (e.g. when performing measurements along public roads, on building sites etc.). Otherwise do not use the device.
- Observe the storage and operating conditions (see chapter Technical data).

Intended use

The device is intended for measuring the size and number of particles in the air.

The device is also intended for measuring the carbon monoxide concentration of the air in closed rooms.

The device is also intended for measuring the formaldehyde concentration of the air in closed rooms.

Improper use

The device may not be used for measurements in liquids.

The device may not be used in potentially explosive atmospheres, when wet or very humid.

Any unauthorised changes, modifications or alterations to the device are forbidden.

Personnel qualifications

People who use this device must:

- be aware of the dangers that occur when working in environments contaminated with formaldehyde.
- be aware of the dangers that occur when working in environments contaminated with carbon monoxide.
- have read and understood the operating manual, especially the Safety chapter.

Residual risks



Warning of explosive substances

Do not expose the battery to temperatures above 45 °C! Do not let the battery come into contact with water or fire! Avoid direct sunlight and moisture. There is a risk of explosion!



Warning of laser radiation

Laser class 1

The laser is encapsulated. Do not open the device to prevent direct contact with the laser and the emitted radiation!



Warning

Risk of suffocation! Do not leave the packaging lying around. Children may use it as a dangerous toy.



Warning

The device is not a toy and does not belong in the hands of children.



Warning

Dangers can occur at the device when it is used by untrained people in an unprofessional or improper way! Observe the personnel qualifications!



Caution

Keep a sufficient distance from heat sources.

Notice

To prevent damages to the device, do not expose it to extreme temperatures, extreme humidity or moisture.

Notice

Do not use abrasive cleaners or solvents to clean the device.

Examples for carbon monoxide concentration in the air

Examples for carbon monoxide concentrations and their effects:

0 to 1 ppm	Normal background levels
9 ppm	Max. permissible concentration for interior spaces
35 ppm	Max. average amount to which one may be exposed over a period of 8 hours. *
100 ppm	Exposure limit, persons ought to leave enclosed spaces. *
150 ppm	Slight headache after 1.5 hours
200 ppm	Mild headache, fatigue, nausea and dizziness
400 ppm	Frontal headache, life-threatening after 3 hours
800 ppm	Dizziness, nausea, convulsions, death within 2 to 3 hours
1600 ppm	Nausea within 20 minutes, death within 1 hour
3200 ppm	Headache, dizziness and nausea within 5 to 10 minutes. Death within 25 to 30 minutes.
12800 ppm	Death within 1 to 3 minutes
* according to OSHA = Occupational Safety & Health Association	

Examples for formaldehyde concentration in the air

Formaldehyde is a colourless gas which is often contained in the room air. Depending on the personal sensitivity, it is perceived as a pungent odour above certain concentrations.

Formaldehyde, also referred to as HCHO or methanal, was assigned to the hazard class Carcinogenic/category 1B and Germ cell mutagenic/category 2 with effect from 1 January 2016. Even small quantities of formaldehyde in the room air may affect human health. The consequences include concentration disorders, nervousness, headaches, dizziness, but also nausea, swelling of mucosa, conjunctival irritations and lacrimation. In extremely high concentrations, formaldehyde can cause pneumonia or toxic pulmonary oedema and is therefore fatal.

Moreover, the substance is suspected of having a sensitizing effect on the body with respect to allergies, and of promoting an aggravation of asthmatic symptoms. It is assumed that the adverse health impact of formaldehyde is not caused by the isolated substance but by mixtures of pollutants (VOC/TVOC) containing formaldehyde.

The following specifications serve as guide values, which were determined in international studies. They are not binding since the listed symptoms strongly depend on personal sensitivity!

0.05 to 0.125 ppm	Odour threshold
0.01 to 1.6 ppm	Irritation of mucous membranes (nose, throat) and eyes
2.0 to 3.0 ppm	Stinging in the nose, eyes, throat
4.0 to 5.0 ppm	Bearable for 30 minutes, increasing discomfort, lacrimation
10.0 to 20.0 ppm	Strong lacrimation already after a few minutes of exposure (lasting for up to 1 hour after exposure), immediate breathlessness, coughing, severe burning in throat, nose and eyes
30 ppm	Toxic pulmonary oedema, pneumonia, risk of death!

TVOC – Total Volatile Organic Compounds

Nowadays, interior spaces contain numerous possible sources of volatile organic compounds, so-called VOCs. Such sources include sealants, furniture, varnishes and solvents, insulation material etc.

Every individual volatile organic compound can be associated with specific as well as unspecific health problems. Therefore, there is a maximum limit for the ambient concentration of each of these substances in interior spaces.

Due to the different chemical compositions and the associated different impact potential of each of these substances, an assessment of the overall group of substances is a rather complex issue. However, this is exactly what is tried to be done by way of calculating the sum of the concentrations of these individual compounds, i.e. by determining one collective value, the so-called TVOC value (Total Volatile Organic Compounds).

Owing to the complexity of VOCs, both the individual health effects on the human body and their intensity can be different and vary greatly in certain cases. Therefore, the TVOC concentration and its effects are purely indicative.

Even below the thresholds of an acute individual effect, TVOCs can affect the human well-being and health through so-called combination effects. A long-term exposure to even low TVOC concentrations, particularly to mixtures, can lead to unspecific symptoms and reactions including

- perception of unpleasant odours and tastes
- runny nose and watery eyes
- irritation of eyes, nose, throat
- dry mucous membranes and dry skin, itching
- increased sensitivity to infections of the respiratory tract as well as
- neurotoxic symptoms (fatigue, headaches, reduced mental performance)

and even result in permanent health damage.

TVOC concentration (mg/m ³)	Effect
< 0.20	No irritation or impairment of well-being
0.20 to 3.0	Irritation or impairment of well-being possible in case of interaction with other exposure parameters
3.0 to 25	Exposure results in an effect; headaches possible in case of interaction with other exposure parameters
> 25	Headaches; other neurotoxic effects apart from headaches possible

(Source: German Federal Environmental Agency, Federal Health Bulletin, B. Seifert, Guideline values for indoor air, Springer 1999)

Information about the device

Functional description

The particle counter is designed to measure the size and amount of particles in the air. The detected data can be used for analysing cleanrooms or prove environmental burdens from particulates.

To detect the data, the particle counter sucks in air for an adjustable amount of time and determines the size and amount of particles contained in it.

Particles of the sizes 0.3 µm, 0.5 µm, 1.0 µm, 2.5 µm, 5.0 µm and 10.0 µm are treated equally during this process.

There are three methods of analysis (see also Definitions):

Cumulative:	Amount of all particles up to the selected particle sizes, e.g.: 0.5 µm = 417 means that 417 ppm of the particles have a size of > 0.3 µm to 0.5 µm.
Differential:	Absolute concentration of the different particle sizes per channel and measured volume.
Concentration:	Averaged concentration of the different particle sizes per channel per measured volume.

The detected values for all active particle sizes are displayed on the 2.8 inch colour display simultaneously. In addition, the air burden in one particle size selected by the user is displayed on a colour indication scale. As soon as the particle burden is no longer in the green area of this scale, a beep is emitted (see table Alarm limit values for particle burdens).

In addition to the counted particles, the temperature and relative humidity as well as the dew point and wet-bulb temperature calculated from that information are displayed. Measurements as well as the associated photo and video documentation can be saved in the internal memory of the device or on a microSD card, and then transmitted onto a PC via USB cable.

The device is equipped with an integrated measuring cell with laser (class 3R laser, 780 nm, 1.5-3 mW). Owing to the tamper-proof enclosure it is classified as laser class 1 (DIN EN 60825-1) according to the Technical Regulations of the Occupational Health and Safety Ordinance on Artificial Optical Radiation (*TROS*) devised by the German Federal Institute for Occupational Health and Safety. Maintenance and repair work may only be carried out by trained expert staff observing the legal regulations.

Alarm limit values for particle burden¹⁾

Channel	Green	Yellow (signal beep)	Red (signal beep)
0.3 µm	0 ~ 100000	100001 ~ 250000	250001 ~ 500000
0.5 µm	0 ~ 35200	35201 ~ 87500	87501 ~ 175000
1.0 µm	0 ~ 8320	8321 ~ 20800	20801 ~ 41600
2.5 µm	0 ~ 545	546 ~ 1362	1363 ~ 2724
5.0 µm	0 ~ 193	194 ~ 483	484 ~ 966
10 µm	0 ~ 68	69 ~ 170	170 ~ 340

¹⁾ The limit value ranges listed for the respective channel were determined on the basis of ISO 14644-1 and in connection with practical experience values. They are in no way legally binding and have a merely orientating function.

Device depiction

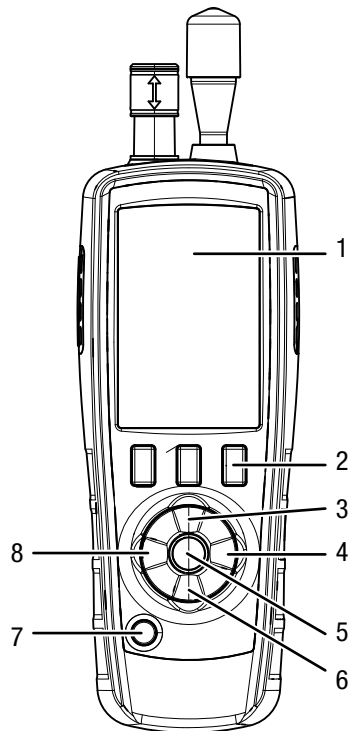

No.	Designation
1	Colour display
2	Function keys "F1", "F2" and "F3"
3	Arrow key up
4	"ENTER" key
5	"RUN/STOP" key
6	Arrow key down
7	"On/Off" key
8	"ESC" key

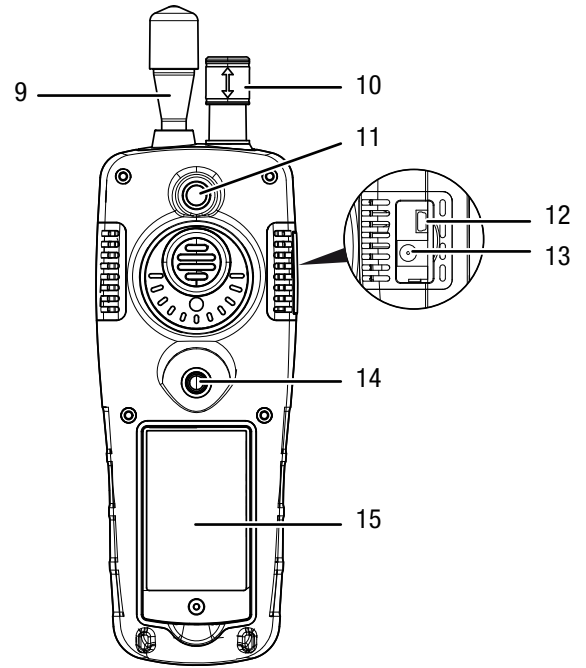

No.	Designation
9	Measuring funnel
10	Temperature and humidity sensor
11	Camera
12	USB port
13	Electrical connection
14	Tripod thread
15	Battery compartment

Technical data

Parameter	Value
Model	PC220
Dimensions (H x W x D)	240 mm x 75 mm x 57 mm
Weight	570 g
Light source	Laser class 1 (class 3R laser enclosed in a way to prevent tampering, 780 nm, 1.5-3 mW, classified according to DIN EN 60285-1 and the Technical Regulations of the Occupational Health and Safety Ordinance on Artificial Optical Radiation (TROS))
PC interfaces	USB connection
Tripod thread	1/4 inch – 20 UNC
Storage conditions	-10 °C to +50 °C at < 95 % RH (non-condensing)
Display	2.8 inch colour LCD display with background illumination, 320 x 240 pixels
Functions	Maximum, minimum and average value display, measured value hold function, alarm function, language selection, °C/°F switch, photo or video recording
Image format, resolution	JPEG, 640 x 480 pixels
Video format, resolution	3GP, 320 x 240 pixels
Data storage	5000 data records on the internal flash memory (optional memory expansion with a microSD card: up to 16 GB)
Energy	
Battery	Polymer LI-ION battery
Operating time	approx. 4 hours of continuous operation
Charging time	approx. 2 hours with an alternating current adapter
Automatic switch-off	3 minutes, 15 minutes or 60 minutes
Automatic screen switch-off	90 seconds, 2 minutes or 4 minutes
Temperature measurement	
Temperature range	0 °C to 50 °C (32 °F to 122 °F)
Temperature accuracy	±0.5 °C (0.9 °F) at 10 °C to 40 °C (50 °F to 104 °F) ±1.0 °C (1.8 °F) in other temperature ranges
Dew point temperature range	0 °C to 50 °C (32 °F to 122 °F)
Dew point temperature accuracy	±0.5 °C (0.9 °F) at 10 °C to 40 °C (50 °F to 104 °F) ±1.0 °C (1.8 °F) at other temperature ranges
Wet-bulb temperature range	0 °C to 80 °C (32 °F to 176 °F)
Wet-bulb temperature accuracy	±1.0 °C (1.8 °F)

Parameter	Value
Humidity measurement	
Humidity level measuring range	0 % RH to 100 % RH
Humidity level accuracy	±3 % RH at 40 % to 60 % ±3.5 % RH at 20 % to 40 % and 60 % to 80 % ±5 % RH at 0 % to 20 % and 80 % to 100 %

Parameter	Value
Particle counter	
Channels (detectable particle sizes)	0.3 µm, 0.5 µm, 1.0 µm, 2.5 µm, 5.0 µm, 10.0 µm
Flow rate	2.83 l/min. (0.1 ft ³ /min.) (=> 0.99 l/21 s) controlled by internal pump
Counter mode	Cumulative, differential, concentration
Counting efficiency	50 % at 0.3 µm; 100 % for particles > 0.45 µm (according to ISO 21501)
Coincidence loss	5 %, 2 million particles per 28.3 litres
Zero check	1 count/5 minutes (according to JIS B9921)
Start delay	1 to 100 seconds
Sample inlet	Isokinetic probe
Calibration	Using monodisperse latex particles (PSL particles; compliant with NIST)
Light source of the measuring cell	Laser class 1 (class 3R laser enclosed in a way to prevent tampering, 780 nm, 1.5-3 mW, classified according to DIN EN 60285-1 and the Technical Regulations of the Occupational Health and Safety Ordinance on Artificial Optical Radiation (TROS))

Mass concentration	
Channels	PM2.5 / PM10
Measuring range	0 to 2000 µg/m ³
Resolution	1 µg/m ³

Parameter	Value
Formaldehyde (HCHO)	
Measuring range	0.01 to 5.00 ppm
Accuracy	±5 % FS
Resolution	0.01 ppm
Carbon monoxide (CO)	
Measuring range	10 to 1000 ppm
Accuracy	±5 % FS
Resolution	1 ppm

Scope of delivery

- 1 x Particle counter PC220
- 1 x Mini tripod
- 1 x USB connecting cable + software
- 1 x Getting started guide
- 1 x Transport case
- 1 x Zero filter + connection hose
- 1 x Charger

Transport and storage

Notice

If you store or transport the device improperly, the device may be damaged.
 Note the information regarding transport and storage of the device.

Transport

For transporting the device use a suitable bag to protect it from external influences.

The supplied Li-ion batteries are subjects to the requirements of dangerous goods legislation.

Observe the following when transporting or shipping Li-ion batteries:

- The user may transport the batteries by road without any additional requirements.
- If transport is carried out by third parties (e.g. air transport or forwarding company), special requirements as to packaging and labelling must be observed. This includes consulting a dangerous goods specialist when preparing the package.
 - Only ship batteries if their housing is undamaged.
 - Mask open terminals with tape and pack the battery in a way that it cannot move inside the packaging.
 - Please also observe any other national regulations.

Storage

When the device is not being used, observe the following storage conditions:

- dry and protected from frost and heat.
- protected from dust and direct sunlight.
- with a cover to protect it from invasive dust, if necessary.

Operation

Switch-on

1. Press and hold the "On/Off" key  until the colour display starts.
 - ⇒ The device is ready for operation as soon as the following start screen is shown:



2. In the start screen, select the desired measuring option by pressing Enter. Alternatively, you can use the F1, F2 or F3 keys to make various settings or call up the help.

Operating elements

The following operating elements are available:

Use the ▲ ▼ buttons to select the desired measuring option or a menu item.

Press "ENTER" to confirm your selection.

Press "ESC" to return to the previous menu at any time.



Use the "F1", "F2" and "F3" buttons to select various functions depending on the current screen.

Setting the language

1. Press "F2" in the start screen.
 - ⇒ The SYSTEM SET menu opens.
2. Press ▼ 2 times and confirm by pressing "ENTER".
 - ⇒ The Language menu opens.
3. Use the ▲ ▼ buttons to select the appropriate language.
4. Press "ESC" twice.

Start screen

You can open the following menus from the start screen:

	"F1" button	MEMORY SET – saved data
	"F2" button	SYSTEM SET – system settings
	"F3" button	Info – Information about the device
4	"ENTER" button	"Measurement" screen

MEMORY SET – saved data

The following submenus are available in the MEMORY SET menu:

Picture	Show images
Video	Show videos
Particle Logs	Show measurement logs

SYSTEM SET – system settings

The following submenus are available in the SYSTEM SET menu:

Data/Time	Set date and time
Font Colour	Set font colour
Language	Setting the language
Brightness	Set screen brightness
Auto Power Off	Set automatic switch-off
Display Timeout	Set automatic display switch-off
Alarm Select	Enable/disable alarm
Memory Status	Display memory use
Factory Setting	Reset to factory settings
Units	Switch unit for temperature

"Info" screen

This screen shows both information about the particle counter and also general information about particle measurement. Use the "F1" and "F3" buttons to scroll through the displays.

"Measurement" screen

The "Measurement" screen contains the following information:

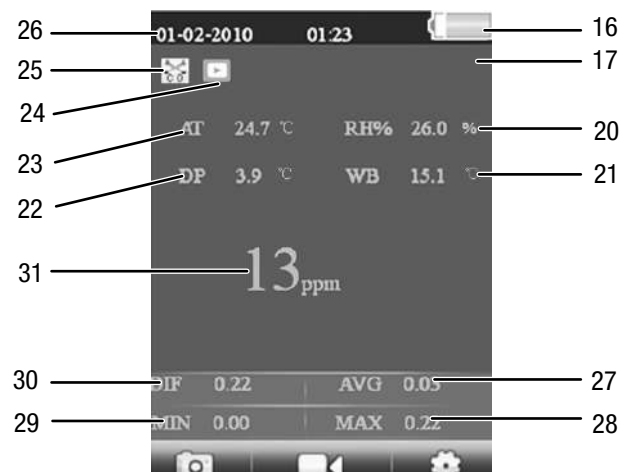
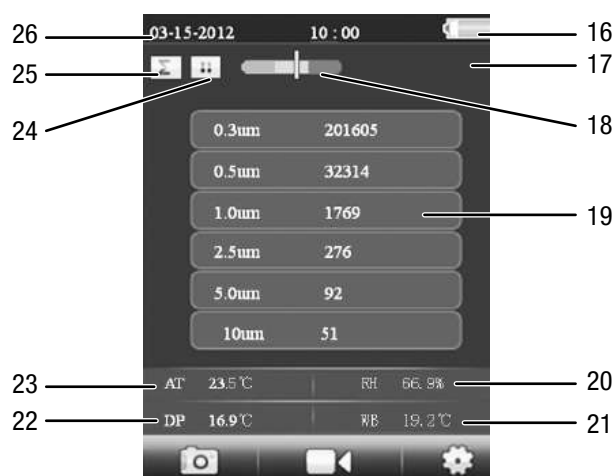

No.	Designation
16	Battery indicator
17	Start delay Measurement duration Measurement interval
18	Indicator scale for particle burden
19	Size and amount of particles
20	Relative humidity
21	Wet-bulb temperature
22	Dew point
23	Temperature
24	Measurement in progress / Measurement stopped
25	Method of analysis/measuring mode: HCHO measurement CO measurement Particle measurement cumulative Particle measurement differential Particle measurement concentration Particle measurement mass concentration
26	Date and time
27	Average
28	Maximum
29	Minimum
30	Difference
31	Measurement value indication

You can open the following menus from the "Measurement" screen:

	"F1" key	Start photo function
	"F2" key	Start video function
	"F3" key	Open measurement settings: Particle Set – measurement settings for particles CO SET – measurement settings for carbon monoxide
/ CL		HCHO SET – measurement settings for formaldehyde CL – Reset measured values after pressing "F3" for approx. 3 s. Is confirmed by an acoustic signal.
5	RUN/STOP key	"Measurement" screen

Particle Set – measurement settings

The following submenus are available in the "Particle Set" menu:

Sample Time	Set measurement duration
Start Delay	Set start delay
Channel Display	Show/hide individual particle sizes by pressing "ENTER"
Ambient Temp/%RH	Enable/disable temperature and relative humidity
Sample Cycle	Set number of measurement repetitions
MassCon/Particle	Select measuring mode Particles (Particle) or mass concentration (Mass concentration)
Sample Mode	Set method of analysis cumulative, differential, concentration
Interval	Set measurement interval
Level Indication	Select particle size for indicator scale for particle burden

Example: Set measurement duration

- Use the ▼ ▲ keys to select the "Sample Time" menu and then press "ENTER" to confirm.
⇒ The "Sample Time" menu opens.
- Press the "ENTER" key.
⇒ The measurement duration glows blue.
- Use the ▼ ▲ keys to set the measurement duration and confirm by pressing "ENTER".
⇒ The measurement duration not longer glows blue. The set value is saved.

HCHO SET – measurement settings for formaldehyde

The following submenus are available in the "HCHO SET" menu:

Start Delay	Set start delay
HCHO Alarm	Switch HCHO alarm (acoustic) on/off Specify alarm threshold
Max/Min	Enable/disable max/min value
Average/Dif	Enable/disable average value/difference
Ambient Temp/%RH	Enable/disable temperature and relative humidity
Dewpoint/Wetbulb	Enable/disable dew point/wet-bulb

CO SET – measurement settings for carbon monoxide

The following submenus are available in the "CO SET" menu:

Start Delay	Set start delay
CO Alarm	Switch CO alarm on/off Specify alarm threshold
Max/Min	Enable/disable max/min value
Average/Dif	Enable/disable average value/difference
Ambient Temp/%RH	Enable/disable temperature and relative humidity
Dewpoint/Wetbulb	Enable/disable dew point/wet-bulb

Carrying out a measurement

- Slide the protective cap of the temperature sensor (10) down.
- Remove the protective cap from the measuring funnel (9).

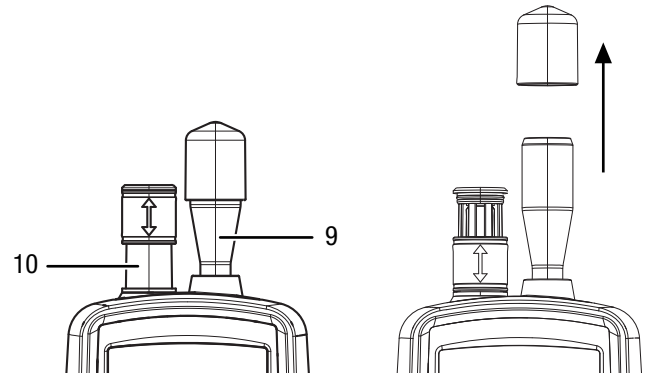



- Press "ENTER" in the start screen.
⇒ The "Measurement" screen opens.
- Press the "RUN/STOP" button.
⇒ Depending on the configuration, start delay, measurement duration and measurement interval are shown consecutively.
⇒ The number of measured particles and their size is shown.

After each measurement, a measurement log is automatically created. If you also want to take a photo or record a video, proceed as described in the next sections.





Recording a video

Videos can be recorded while a measurement is in progress.

- ✓ The screen for the respective measurement (particles, HCHO or CO) is active.
- 1. Press "F2"  to start the video function.
- 2. Press "F2"  again to start recording a video.
 - ⇒ The duration of the video is shown at the top of the screen.
- 3. Press "F2"  to stop recording the video.
 - ⇒ The message "Saving File" appears in the display. The video is saved.
- 4. Press "ESC" to exit the video function.

Taking a photo

Photos can be taken while a measurement is in progress.

- ✓ The screen for the respective measurement (particles, HCHO or CO) is active.
- 1. Press "F1"  to start the photo function.
- 2. Press "F2"  again to take a photo of the current display.
 - ⇒ The photo is displayed.
 - ⇒ The measurement continues in the background.
- 3. You can save the photo by pressing "F1"  , or delete it by pressing "F3"  .
- 4. Press "ESC" to exit the photo function.

Inserting a microSD card

The storage capacity of the device can be expanded by using a microSD card. To insert a microSD card, proceed as follows:

1. Switch off the device.
2. Loosen the screw and open the battery compartment.
3. Remove the battery.

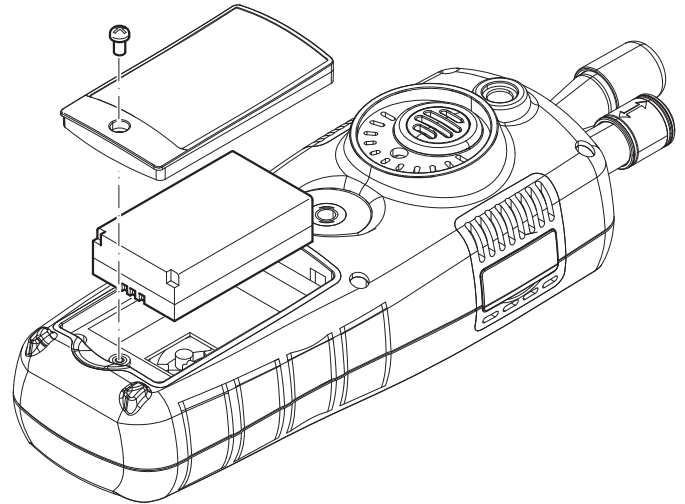

4. Open the cover for the memory card.

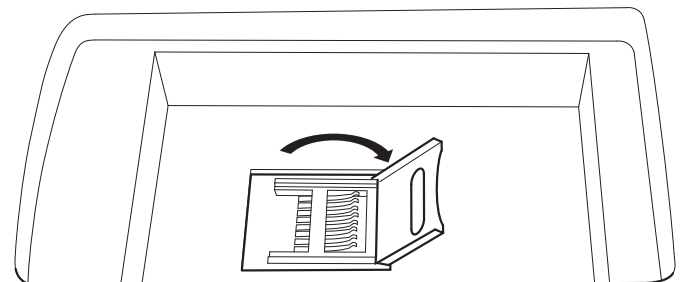

5. Insert a memory card and close the cover.

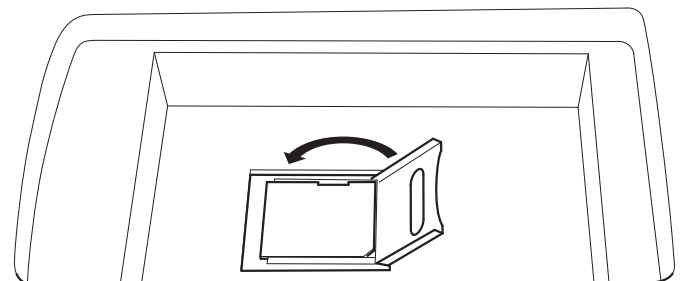

6. Put the battery back in.
7. Close the battery compartment and screw it closed again.

Cleaning the sensor (internal calibration)

If the device is used in heavily contaminated environments, the sensor must be cleaned with the supplied zero filter.

To do so, please proceed as follows:

1. Unscrew the metallic measuring funnel from the device.
2. Screw the calibration hose onto the suction nozzle and attach the zero filter.

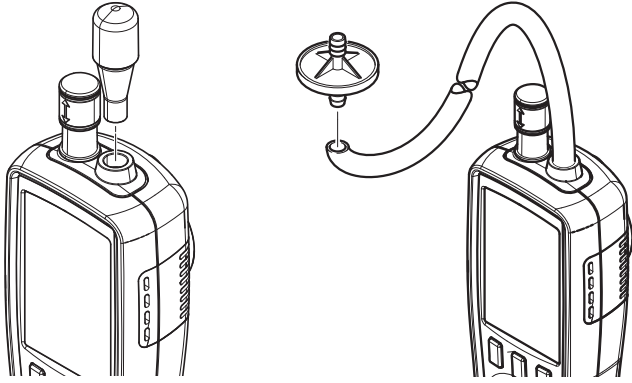

3. Now, carry out a measurement in the "Cumulative" particle measurement mode until "0" is shown in each channel.
4. The calibration process should not take more than 5 minutes. If the desired zero values are not reached in all channels within that time, please contact the Trotec customer service.

Switch-off

1. Press and hold the On/Off key  until the colour display turns off.
⇒ The device has switched itself off.
2. Slide up the protective cap of the temperature sensor (10).
3. Put the protective cap on the measuring funnel (9).

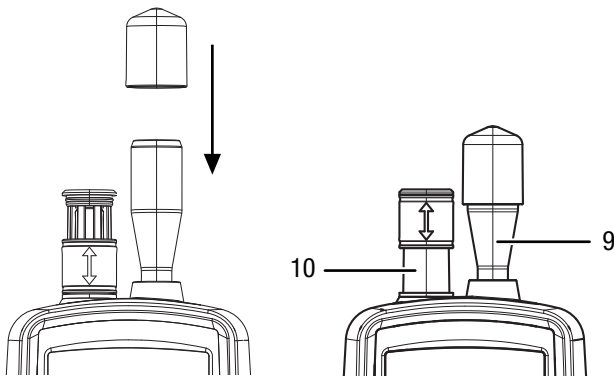

Software

The supplied free software is designed for useful basic functionalities. Trotec assumes no liability with regard to this free software and also provides no support on that score. Trotec accepts no liability concerning the use of this free software and is under no obligation to make adjustments or to further develop updates or upgrades.

Connecting a USB cable

Saved measurement logs, photos and videos can be transferred to a PC with the supplied USB cable.

To connect the USB cable to the device, proceed as follows:

1. Open the rubber side cover.
2. Connect the USB cable to the device.

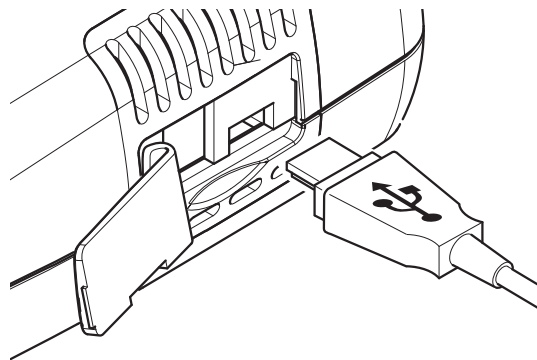

Maintenance and repair



Warning of laser radiation

Laser class 1

The laser is encapsulated.

Do not open the device to prevent direct contact with the laser and the emitted radiation!

Cleaning

Clean the device with a soft, damp and lint-free cloth. Ensure that no moisture enters the housing. Do not use any sprays, solvents, alcohol-based cleaning agents or abrasive cleaners, but only clean water to moisten the cloth.

Repair

Do not modify the device or install any spare parts. For repairs or device testing, contact the manufacturer.

Charging the battery

The battery is partially charged upon delivery to avoid damage to the battery caused by a deep discharge.



Warning of electrical voltage

Before each use of the charger or power cable, check for damages. If you notice damages, stop using the charger or power cable!

Notice

The battery can be damaged in case of improper charging.

Remove the charger's mains plug before inserting or removing the battery.

Never charge the battery at ambient temperatures below 10 °C or above 40 °C.

The battery should be charged prior to initial start-up and when the battery is low. To do so, please proceed as follows:

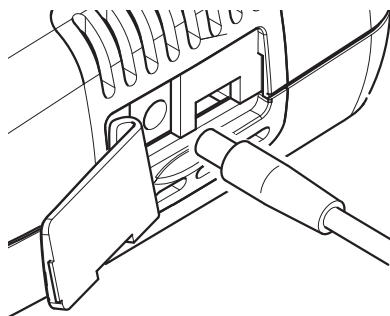

1. Open the rubber side cover.
2. Attach the charger.



3. The loading screen is shown on the display. When the battery is fully loaded, the battery symbol is completely green.

Deleting data

To remove saved data from the internal memory or the microSD card, proceed as follows:

1. Press "F2" in the start screen.
 - ⇒ The SYSTEM SET menu opens.
2. Use the ▼ ▲ keys to select the "Memory Status" menu and then press "ENTER" to confirm.
 - ⇒ The Memory Status menu opens.
3. Use the ▼ ▲ keys to select either the device memory or the microSD card.
 - ⇒ The memory usage is shown below the selection.
4. Press "F1"  to start deleting all data from the selected memory.
 - ⇒ Press "F1" again to confirm the deletion.
 - ⇒ Press "F3"  to cancel the deletion.
5. Press ESC to exit the menu.

Resetting factory settings

To return the device to the state it was in when it left the factory, proceed as follows:

1. Press "F2" in the start screen.
 - ⇒ The SYSTEM SET menu opens.
2. Use the ▼ ▲ keys to select the "Factory Setting" menu and then press "ENTER" to confirm.
 - ⇒ The Factory Setting menu opens.
3. Press ▼ once and confirm by pressing "ENTER".
 - ⇒ The device is reset to factory settings.
 - ⇒ Photos, videos and measurement logs on the internal memory or on the microSD card remain unaffected.

Disposal



The icon with the crossed-out waste bin on waste electrical or electronic equipment stipulates that this equipment must not be disposed of with the household waste at the end of its life. You will find collection points for free return of waste electrical and electronic equipment in your vicinity. The addresses can be obtained from your municipality or local administration. For further return options provided by us please refer to our website www.trotec24.com.

The separate collection of waste electrical and electronic equipment aims to enable the re-use, recycling and other forms of recovery of waste equipment as well as to prevent negative effects for the environment and human health caused by the disposal of hazardous substances potentially contained in the equipment.

You are responsible for deleting any personal data stored on the waste equipment to be disposed of.



Li-Ion

In the European Union, batteries and accumulators must not be treated as domestic waste, but must be disposed of professionally in accordance with Directive 2006/66/EC of the European Parliament and of the Council of 6 September 2006 on batteries and accumulators. Please dispose of batteries and accumulators according to the relevant legal requirements.

PROMAT (HK) Limited 寶時 (香港) 有限公司

☎ : 2661 2392 📞 : 5196 8860 ✉ : info@promat.hk 🌐 : http://www.promat.hk

