



# jumboweigher



A popular choice among steel service centers and other industrial manufacturers, the Jumboweigher crane scale from Straightpoint offers a cost-effective alternative to its more expensive rivals from MSI and Intercomp. The Jumboweigher series of crane scales offer high capacity, quality, accuracy, and safety at low capacity prices and are utilized worldwide in a variety of manufacturing and industrial applications.

As with all Straightpoint products each Jumboweigher crane scale receives superior electronics, excellent build quality and certified calibration and proof testing. The heavy duty crane scale is extremely accurate, and is manufactured from quality materials, featuring a high strength aluminum alloy outer housing.

Each unit is equipped with a large and bright LED display that can be easily read even in direct sunlight. The simple to use remote features oversized buttons for use with gloved hands and provides for control of tare and hold functions. Battery charging intervals are extended by the standby power saving mode as well as the automatic shut off feature. As with all Straightpoint products each Jumboweigher is safety tested and is supplied with certification of calibration and proof testing.

If you are looking for a high quality, cost-effective crane scale and are unwilling to give up features and safety, look no further than the Jumboweigher crane scale from Straightpoint.

## Features and benefits:

- Large Bright LED Display
- High Accuracy
- Aluminum Housing
- Power Saving Mode
- Tare
- Hold Function
- Large keys make operation simple even if wearing gloves

# imperial specifications

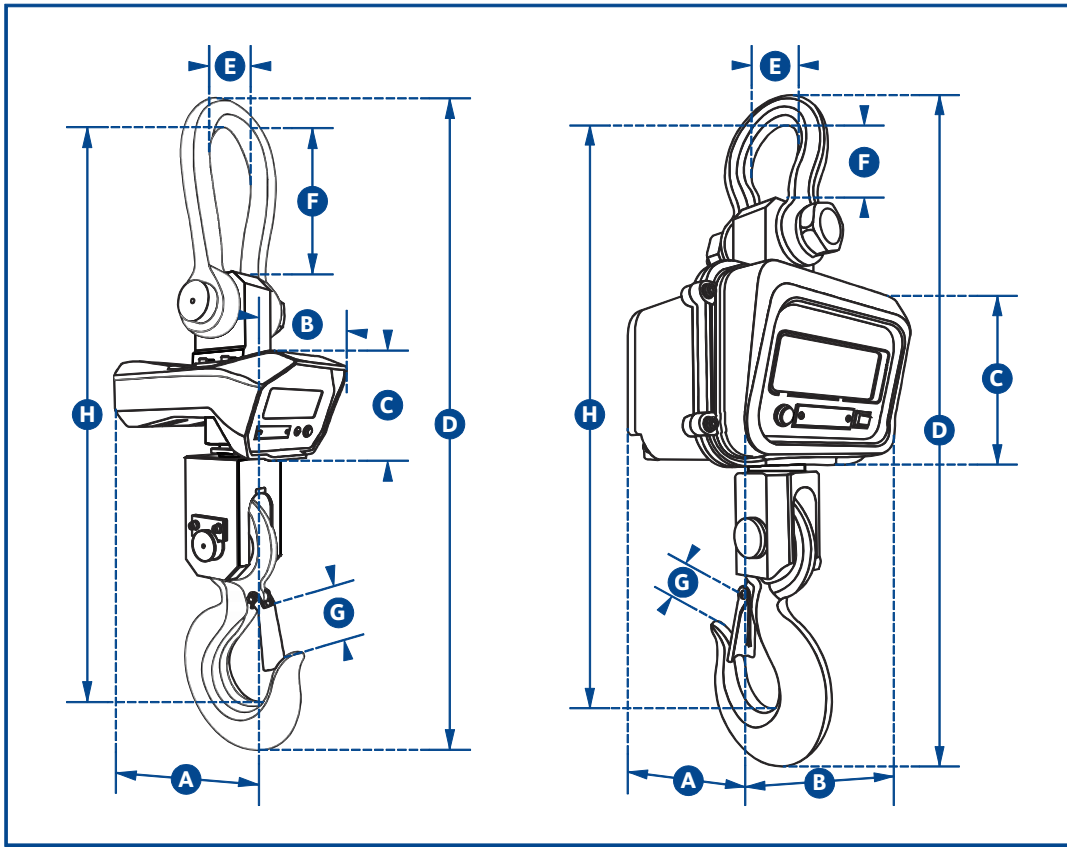

# jumboweigher

Part Number	JW5TU	JW10TU	JW20TU
Capacity	11000lb	22000lb	44000lb
Resolution	5lb	10lb	20lb
Units		lbs	
Weight	40lb	64lb	165lb
Safety Factor		5:1	
Battery Type	Internal rechargeable		
Battery Life	20 hours		
Operating Temp	14°F to 104°F		
Accuracy	±0.3% of applied load		
Display Type	1.18" LED		
Protection	NEMA 4		
Dimension A	7.68	7.68	13.98
Dimension B	10.04	10.04	9.06
Dimension C	7.09	7.09	6.50
Dimension D	28.15	30.71	43.90
Dimension E	2.83	3.54	5.51
Dimension F	3.54	4.33	9.06
Dimension G	1.42	1.97	2.76
Dimension H	23.43	25.98	38.58



**PROMAT (HK) Limited 寶時(香港)有限公司**  
 901 New Trend Center, 704 Prince Edward Road East, SPK, Kln, HK  
 香港九龍新蒲崗太子道東704號新時代商業中心901室  
 TEL: (+852) 2661 2392 FAX: (+852) 2661 2086  
 Email: sales@promat.hk http://www.promat.hk

